



ANCHOR BOLTS

STEEL AND GALVANIZED STEEL ANCHOR BOLTS

Catalog Number	
Project	Type



FEATURES & SPECIFICATIONS

ANCHOR BOLTS — Techlight anchor bolts are constructed out of ASTM F1554 Grade 55 Steel. Available in oiled raw finish and galvanized finish. Set includes 2 nuts and 2 flat washers per bolt for installation. Sold as a set of four (4) anchor bolts.

See below for anchor bolt projection table.

FINISH — Techlight anchor bolts are available in oiled/raw finish, and fully galvanized per ASTM A153 Class C with a hot-dip galvanized finish.

ORDERING INFORMATION

Choose the bold face options for the appropriate configuration for your application and enter on the line above each fixture attribute.

EXAMPLE:

PAB 3430 G

PAB		
ANCHOR BOLTS	SIZE	FINISH
PAB	3418 = 3/4" Ø X 18" LG 3430 = 3/4" Ø X 30" LG 136 = 1" Ø X 36" LG 12542 = 1 1/4" Ø X 42" LG 1554 = 1 1/2" Ø X 54" LG	(blank) = Raw/Oiled G = Galvanized

ANCHOR BOLT PROJECTION

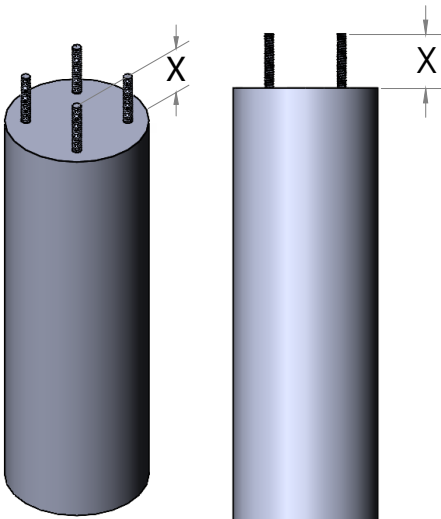

ANCHOR BOLT	SIZE	X = PROJECTION	MATERIAL SPEC
PAB3418	3/4" Ø X 18" LG	4"	ASTM F1554 GD 55 STL
PAB3430	3/4" Ø X 30" LG	4"	ASTM F1554 GD 55 STL
PAB136	1" Ø X 36" LG	4"	ASTM F1554 GD 55 STL
PAB12542	1 1/4" Ø X 42" LG	6"	ASTM F1554 GD 55 STL
PAB1554	1 1/2" Ø X 54" LG	6 1/2"	ASTM F1554 GD 55 STL

ANCHOR BOLTS Steel and Galvanized Steel Anchor Bolts

DIMENSIONS

PAB3418

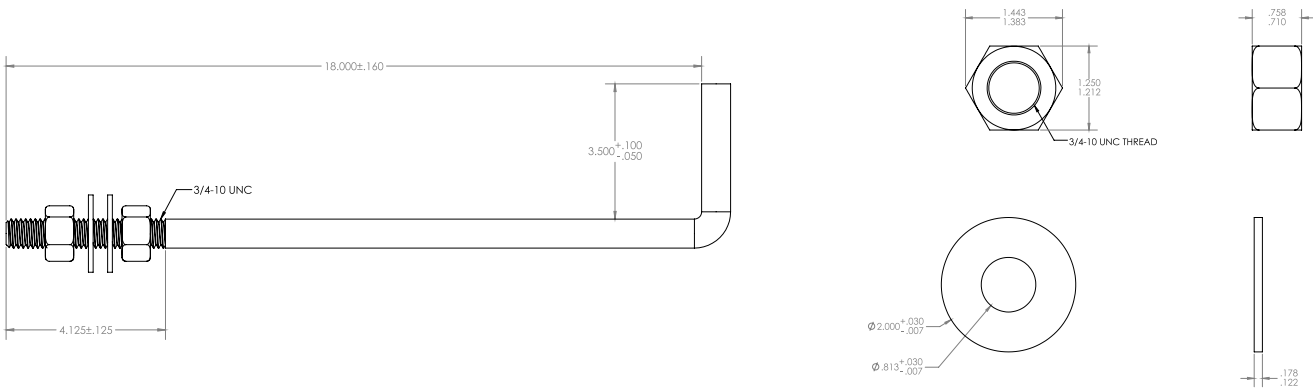

PAB3430

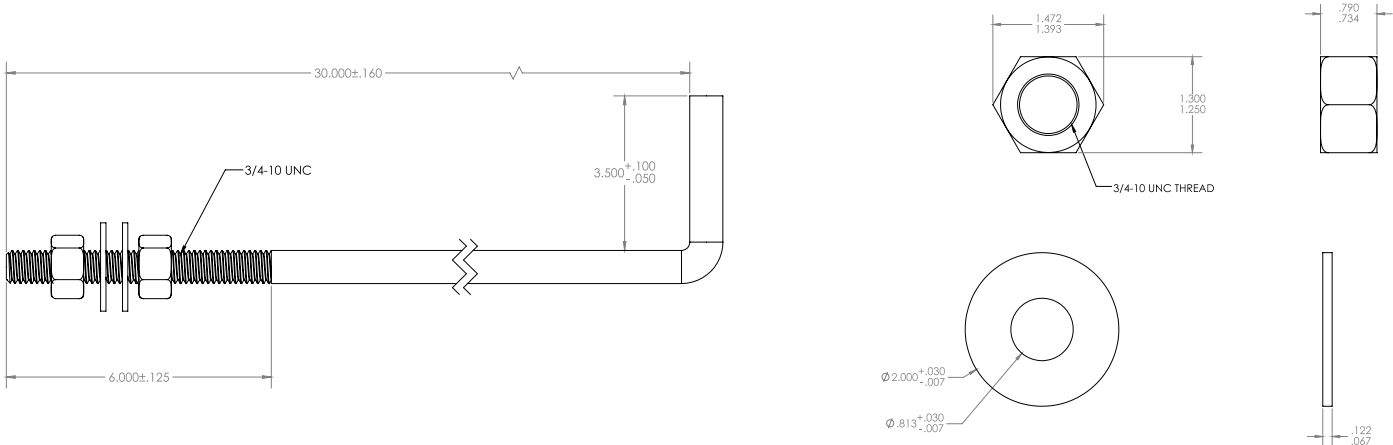

PAB136

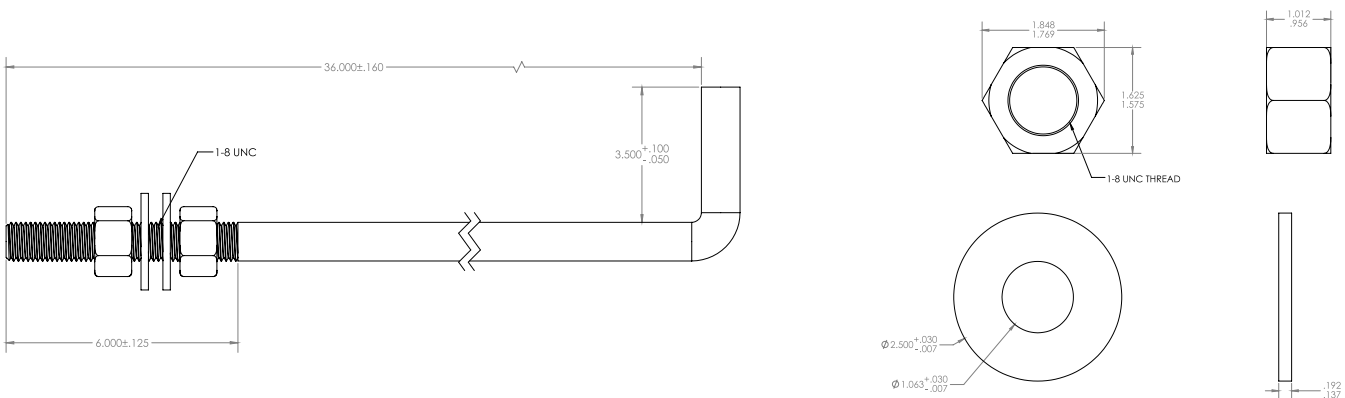

TECHLIGHT
GROUNDED IN ILLUMINATION

2707 SATSUMA | DR. DALLAS, TX 75229 | PH: 800.225.0727 | www.techlight.com

ANCHOR BOLTS Steel and Galvanized Steel Anchor Bolts

DIMENSIONS (cont.)

PAB12542

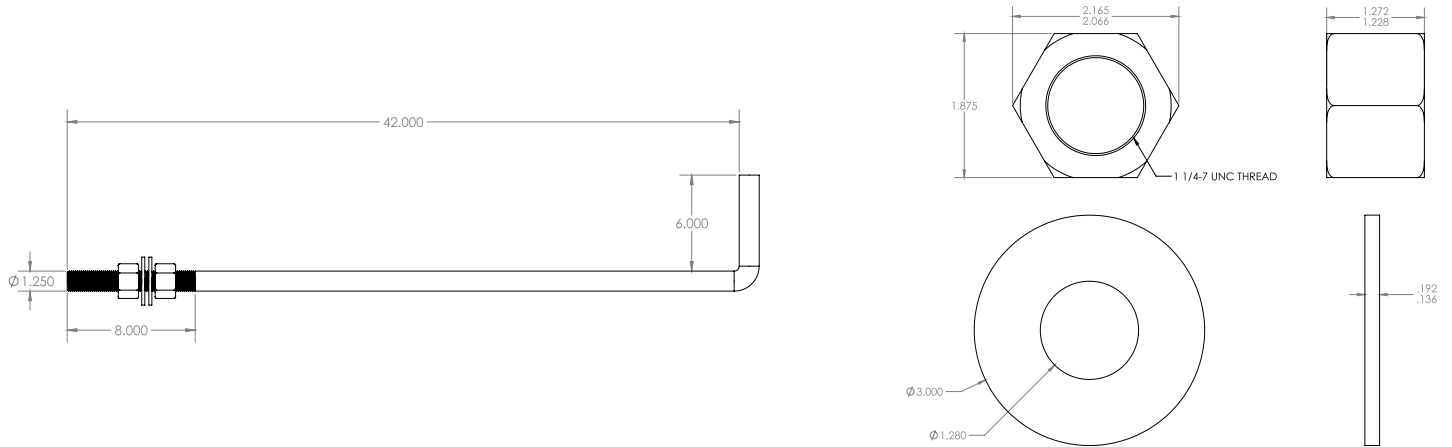

PAB1554 (SHOWN WITH RIGID STEEL TEMPLATE)

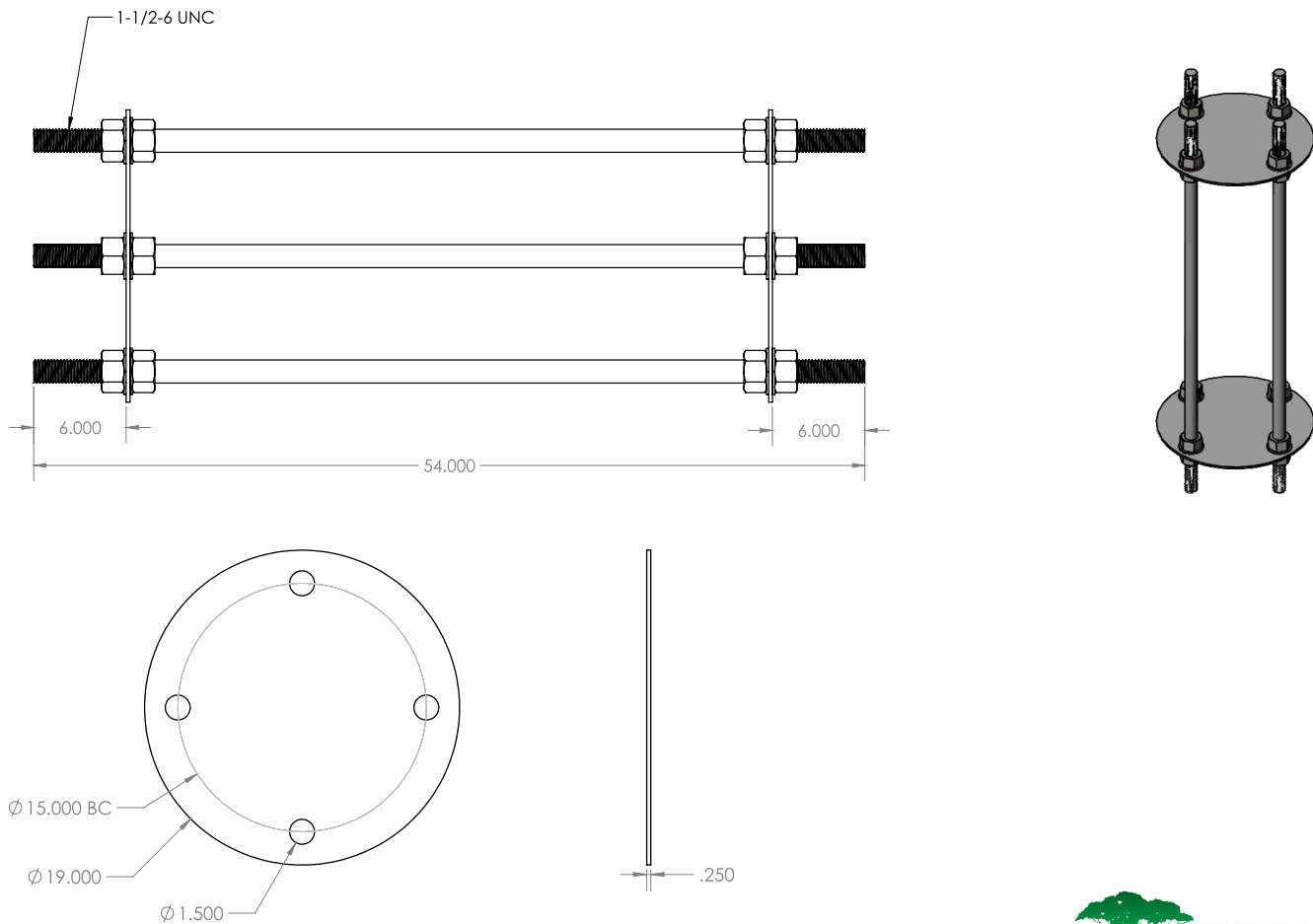

2707 SATSUMA | DR. DALLAS, TX 75229 | PH: 800.225.0727 | www.techlight.com